

# MulePAC PROCEDURES

**1. BOTTOM TRAY:** Begin with feet down, tan lip of tray facing out, and all straps cleared away from tray liner channel. Load cargo on tray deck with forklift or, after step 2, by hand.

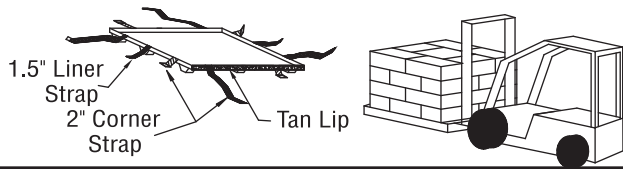

**2. LINER:** With Document Pouch above tan lip of tray, attach liner to tray with 1.5" liner straps while making sure both liners (inside and outside) are fully seated in the tray liner channel on all sides.

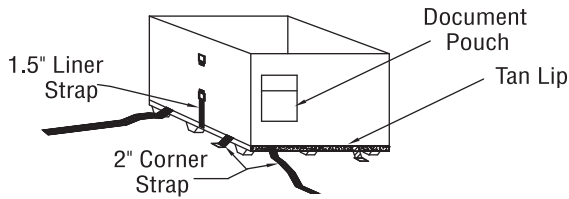

**3. TOP TRAY:** With tray feet up, rotate tray so tan lip is over document pouch. Insure that all straps are outside the liner and that both liners are fully seated in the tray liner channel before fastening 1.5" liner straps.

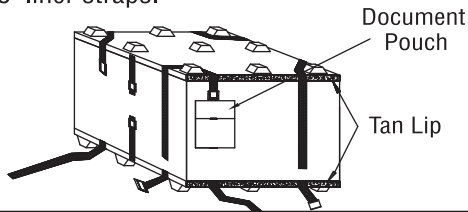

**4. CORNER STRAPS:** Attach and tighten 2" corner straps. Look through tray strap slots to insure both liners are fully seated in the top and bottom tray channels on both sides. Re-tighten all straps.

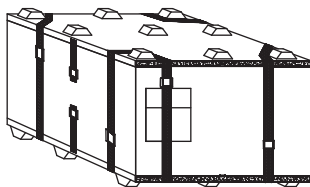

**5. STACKING:** Align document pouches and tan lips of trays when stacking. Always position the heavier load on bottom.

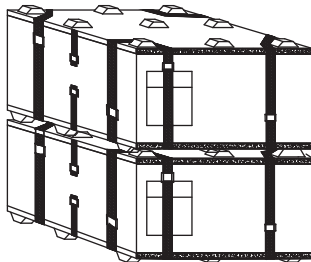

**6. TOP UNLOADING:** Unfasten 2" corner straps and unload MulePAC from the top by releasing top tray 1.5" liner straps and removing top tray. Unload contents by hand.

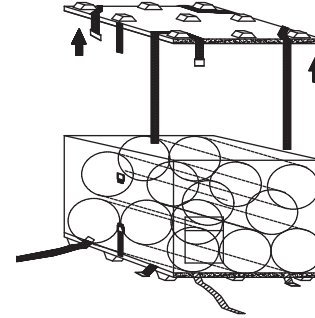

**7. FORKLIFT UNLOADING:** Unfasten 2" corner straps and unload cargo with forklift by releasing bottom tray 1.5" liner straps and lifting liners and top tray up and away from cargo.

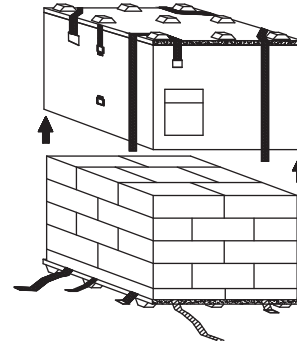

**8. COLLAPSE:** Unfasten all straps, separate inside and outside liners and push side hinges inward to collapse.

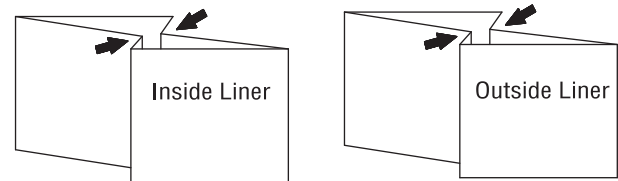

**9. STORAGE/TRANSPORT:** For a stack of 10 collapsed MulePACs, nest 18 trays on bottom with feet facing down and all straps tucked between trays. [Use care to position strap buckles on tray deck, rather than in the tray foot holes, as this would cause the stack to be uneven.] Put collapsed liners (inside and outside) on top of the tray stack. Put 2 nested trays with feet facing up and straps tucked between the trays on top of the collapsed liners. Secure the stack with ratchet straps.

